



INDOOR /OUTDOOR COLOR

CAMERA WITH BUILT-IN 2.4

GHZ WIRELESS TRANSMITTER,

MOTION SENSOR, AND DUAL SENSOR

FLOODLIGHT LAMP HOLDERS LAMP HOLDERS

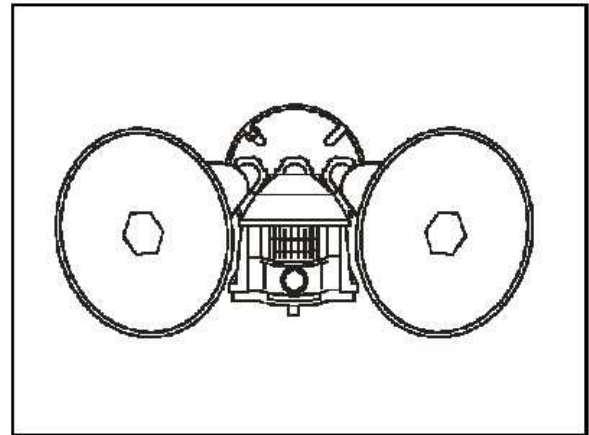

MODEL VT38A OWNER'S MANUAL



## INTRODUCTION

Your Wireless Motion Activated Camera with Dual Floodlights consists of a Color Video Camera with built-in 2.4 GHz transmitter. It is activated by its built-in Motion Sensor so that when someone approaches your home, the camera turns on. At night the connected floodlights also turn on with motion to light up the area that the camera sees (bulbs not included). The camera transmits its picture via its built-in 2.4 GHz transmitter, to a Video Receiver (sold separately) which you connect to a TV anywhere in your home. The Camera sends the wireless signals (even through walls, up to 100 ft.). The Video Receiver converts the signals back to video signals and feeds them through a cable to your TV's Video input.

You can purchase additional Motion Activated Cameras (up to 4) so you can have a multiple camera system. You can then set all cameras to the same channel as the receiver and turn the cameras on and off with X10 remote controls (sold separately) so as to only have one camera turned on at a time, and displayed on your TV.

2

## FRONT, BOTTOM, & SIDE VIEWS

### FRONT VIEW

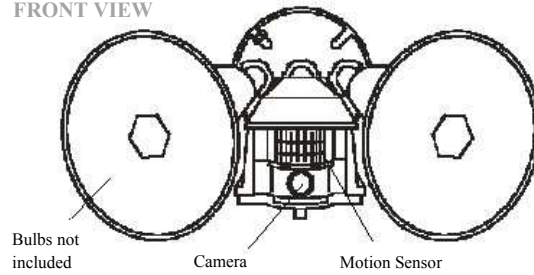

### BOTTOM VIEW (WITH LID CLOSED)

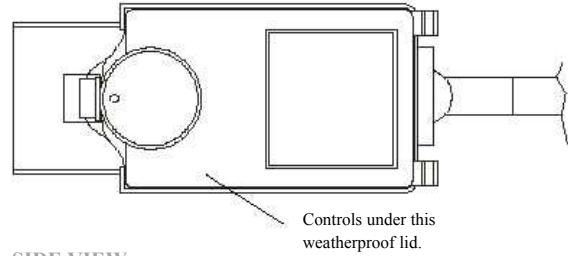

### SIDE VIEW

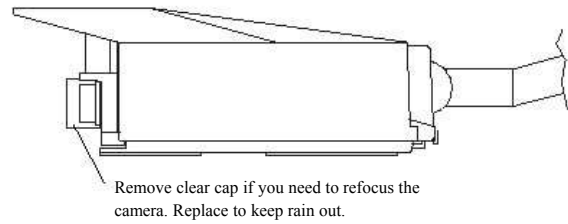

3

## ASSEMBLING THE PARTS

Referring to the diagram below:

1. Screw the base of each lamp holder into the outer holes on the mounting plate.
2. Rotate the locking ring on each lamp holder towards the plate until the lamp holder is secure against the plate.
3. Screw the threaded end of the motion activated camera into the center hole on the mounting plate.
4. Lock the motion activated camera into place using the locking ring.
5. Locate each lamp holder's WHITE wire and one of the WHITE wires from the motion activated camera and twist all three wires together using a wire nut (supplied).
6. Locate each BLACK wire from the lamp holders and connect them both to the BLUE wire from the motion activated camera, again using a wire nut.
7. Make sure no bare whiskers of wire stick out from the wire nuts (cover with electrical tape if necessary).

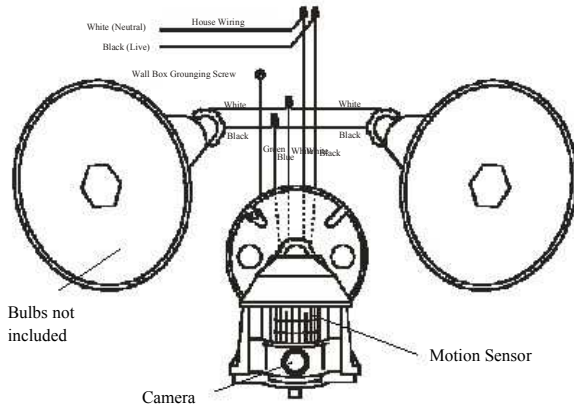

4

## INSTALLING THE ASSEMBLY

You can install the Motion Activated Camera in a wall box that is powered at all times or in a wall box that is controlled by a wall switch, but if it is controlled by a wall switch, make sure you leave the switch on at all times. Turning the switch off will completely disable the motion activated camera.

**CAUTION:** To prevent severe damage to the unit, do not connect it to a wall box that is controlled by any kind of dimmer or remote controlled switch.

**WARNING:** Before making the following connections, be sure the power to the junction box you are installing the motion activated camera into is turned off. If not, a serious shock hazard will exist.

1. Install the gasket (supplied) onto the junction box, and route the house wiring through the gasket.
2. Connect the GREEN wire from the mounting plate to the bare ground wire in the junction box, or ground screw if there is one.
3. Connect the WHITE (Neutral) wire from the motion activated camera assembly to the house wiring's WHITE (Neutral) wire, using a wire nut.
4. Connect the BLACK (Live) wire from the motion activated camera assembly to the house wiring's BLACK (Live) wire, using a wire nut.
5. Make sure no bare whiskers of wire stick out from the wire nuts (cover with electrical tape if necessary).
6. Secure the mounting plate to the junction box using the screws supplied.
7. Secure the insulating ring in each lamp holder and screw a bulb (max. 150W, not supplied) into each lamp holder.

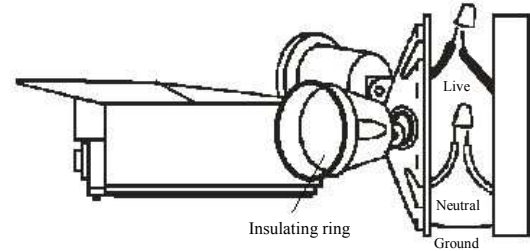

5

## RECEIVER INSTALLATION

### CONNECTING UP THE RECEIVER (SOLD SEPARATELY)

1. Connect a video cable to the VIDEO OUT jack on the VR36A Video Receiver. Connect the other end to your TV's VIDEO IN jack. If your TV does not have a Video IN jack, you will need to purchase an RF modulator, or connect as shown in the diagram below.
2. Plug the Video Receiver's power supply jack into the Video Receiver and plug the power supply into a 120 volt wall outlet.
3. Turn the Video Receiver's power switch (on side of unit) on.
4. Set the channel switch to the same letter as you set on the camera, i.e., A, B, C, or D.
5. Position the Video Receiver in a convenient location such as on top of the TV and orient the antenna so that the flat side points in the direction where you installed the Camera.

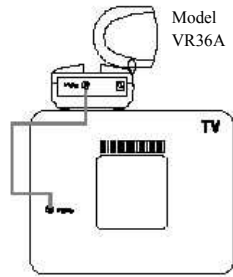

*IF YOUR TV IS ALREADY HOOKED UP TO A DBS RECEIVER OR OTHER A/V DEVICE, OR IF YOUR TV DOES NOT HAVE A VIDEO IN JACK.*

If a DBS Receiver or other A/V component is connected to the TV using a COAX cable, you can connect the Video Receiver to a free LINE IN jack on the component.

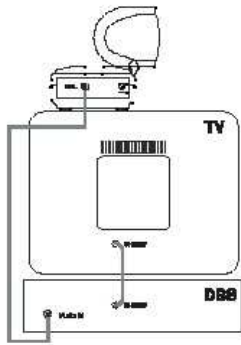

6

## CONTROL PANEL

Your Motion Activated Camera turns on whenever someone approaches your home, and turns off after the time you set on the TIME DELAY dial. When it's dark the connected floodlights also turn on with motion to light up the area that the camera sees (how dark it needs to be is set by the FLOODLIGHT control). The camera transmits its picture to a 2.4 GHz receiver (sold separately) which you connect to your TV. Open the lid on the underside of the Motion Activated Camera to reveal the controls below.

Set the channel switch (A, B, C, or D) to match the setting on the receiver.

Set for when you want the **floodlights** to respond to motion or X10 remote controls. Set towards DARK for them to respond only when it's really dark. (Camera always responds).

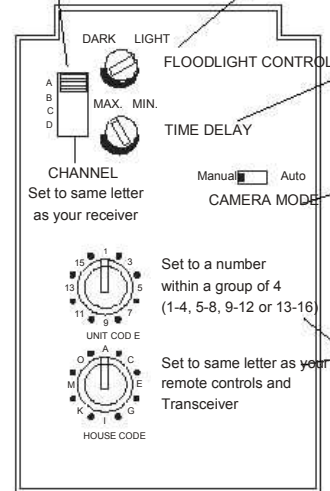

The camera and lights turn off sometime after motion has stopped (adjusted by this dial). Min. = 1 minute, Max. = 30 minutes approx.

Manual: **camera** always on unless you turn it off from an X10 controller. Auto: **camera** turns on with motion and off after motion stops. Floodlights trip with motion then time out regardless of switch position.

Set to a number within a group of 4 (1-4, 5-8, 9-12 or 13-16)

Set to same letter as your

These dials set the code for turning the camera and floodlights on and off from X10 remote controls. Also, when the camera turns on with motion it transmits wireless Radio Frequency (RF) commands to turn off other cameras in its group of 4 (requires a Transceiver, sold separately).

7

## OPERATION

**Set mode switch to Auto.** After you first turn the power on, wait approx. 30 seconds for the motion detector to settle down before you test the unit.

When you first power up, the camera should be on and you will see a picture on your TV. Walk past the unit. The camera turns on if it wasn't on already, or stays on if it was already on. After a time period the camera turns off. You set this time by adjusting the TIME DELAY dial on the unit. Min. = 1 minute, Max. = 30 minutes approx. After the camera turns off, it won't respond to motion again for about 30 seconds.

The floodlights also turn on when you walk past the unit. You set how dark it needs to be for the floodlights to respond to motion by the setting on the FLOODLIGHT control. Set the dial all the way towards DARK if you only want the floodlights to come on when you walk past the unit when it's really dark outside. Side the dial more towards LIGHT if you want the floodlights to turn on when you walk past the unit at dusk. The camera always turns on with motion regardless of the FLOODLIGHT control setting.

If you own any X10 remote controls, set the House Code and Unit Code dials to the codes you want the unit to respond to. For example, if you set the dials to A1, pressing A1-ON and OFF on any X10 remote control turns the camera on and off. If it's dark outside, the floodlights also turn on and off when the correct X10 command is received. You set how dark it needs to be with the FLOODLIGHT control.

If you turn the camera and floodlights on using an X10 remote control, they both stay on until you turn them off from an X10 remote control.

If you own more than one Motion Activated Camera (or other X10 cameras) set each one to a Unit Code within the group 1-4 or 5-8 or 9-12 or 13-16. Then when the Motion Activated Camera sees motion and turns on, it sends a command to turn off the other cameras in its group of 4. (You must not have more than one camera on at the same time or the picture on your TV will be scrambled). Note, a Transceiver, Model TM751 or RR501 (sold separately) is required for multiple camera systems. If you turn any other camera in the group of 4 on from an X10 remote control, the Motion Activated Camera turns off.

**Camera Mode switch set to Manual:** The camera turns on with motion and stays on until you turn it off from an X10 controller. The camera turns on from an X10 controller and stays on until you turn it off from an X10 controller. The camera turns off if you turn on any other camera in its group of 4 (if you own multiple cameras). The floodlights respond to motion as normal and turn off after the TIME DELAY you set. They also respond to remote control commands. You set how dark it needs to be before they respond to motion and remote controls by the setting on the FLOODLIGHT control.

## FINE TUNING OUR SYSTEM

The Wireless Motion Activated Camera usually works best with the flat face of the antenna on the Receiver facing towards the location where you installed the Camera (see diagram below). Sometimes, however, reflections and other effects in the home may affect the signal so that some adjustment of the Receiver antenna may be necessary to get the best picture.

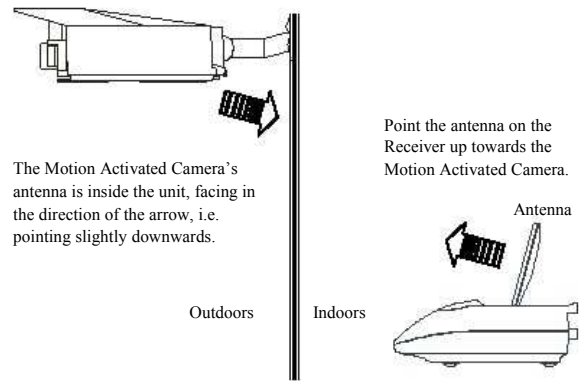

The Motion Activated Camera's antenna is inside the unit, facing in the direction of the arrow, i.e. pointing slightly downwards.

Point the antenna on the Receiver up towards the Motion Activated Camera.

## TROUBLESHOOTING

### If you do not see a picture on your TV:

Check that the receiver and the camera are on the same letter channel (A, B, C, or D). The channel switch on the camera is located under the lid on the bottom of the unit. Make sure you close the lid and screw it tightly shut afterwards. On the receiver the switch is underneath.

There is a power light on the front of the receiver. Check that the power switch on the side of the receiver is ON.

Verify that the connections to your TV are correct. Make sure you are using the appropriate input mode for your TV, try pressing the A-B button or Video button on your TV's remote to change the input mode (consult your TV's owner's manual, if necessary). If you are using the Coax cable (VR31A receiver only), verify that the Receiver and the TV are on the same channel (3 or 4).

If you connected the Receiver to a VCR and then connected the VCR to your TV, you might need to turn the VCR OFF to see the camera picture on your TV. Or you might need to turn the VCR on, AND set it to record the picture from the camera, in order to see the picture on your TV. Or you might need to press the A-B button on your VCR's remote control. Consult your VCR's owner's manual for more information.

### If you get a picture but the quality is poor:

Take a look at what the video signal is passing through or near to get to the receiver. Metal objects and electromagnetic fields can distort the signal. Try to keep the receiver as far away from other devices as the cables allow. In most cases, relocating the receiver a few feet is enough to avoid the source of interference.

Try unplugging/turning off any electromagnetic interference producing devices, such as a microwave oven, baby monitor, computer, wireless LAN, wireless speakers, cordless phone, cell phone, etc.

Other 2.4 GHz devices can distort the camera's picture. If you are experiencing interference between X10 cameras and some other equipment that uses 2.4 GHz, you might want to check the other device's owner's manual for the frequencies of each channel that it uses. X10 cameras use the following frequencies: Channel A: 2.411 GHz, Channel B: 2.434 GHz, Channel C: 2.453 GHz, Channel D: 2.473 GHz. We recommend using a frequency for the other device that is farthest from channel A or D, depending on which side of the band the other device is transmitting.

Otherwise you will need to discontinue use of the device while using the camera.

### If you are having difficulty turning the camera on or off remotely:

Try plugging the transceiver (the white module with the antenna) into a different AC outlet. (Only required for multiple camera systems).

### If the camera is out of focus:

The motion activated camera is shipped preset to be in focus for normal use, but if you want to change the focus you can remove the clear plastic cover and rotate the inner portion of the lens. It might be a bit tight. Try turning it counterclockwise first. If you turn it clockwise do not force or over tighten it. Replace the clear plastic cover to keep the rain out.

### If the floodlights don't turn on with motion:

Check the FLOODLIGHT control setting. Adjust if necessary, towards DARK to make the lights turn on with motion only when it's really dark, or towards LIGHT to turn the floodlights on with motion at dusk. Check that you are walking across the path of the sensor. It is more sensitive in this direction than if you walk towards it. Note, unlike the floodlights, the camera turns on with motion at all times, regardless of the dusk setting.

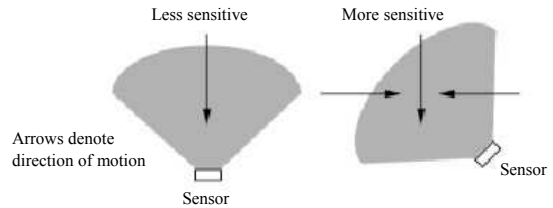

For more help please visit [www.x10.com/support](http://www.x10.com/support)

<b>Specifications</b>	<b>Auto Shutter:</b> 1/60 to 1/15,000 sec.
<b>Imager:</b> CMOS sensor.	<b>Operating Temperature:</b> -4 deg F. to +122 deg. F.
<b>Format:</b> 1/3 inch.	<b>Humidity Limits:</b> 0 - 95%.
<b>Array Size NTSC:</b> 510 X 492.	<b>Field of View:</b> camera 60 deg., motion sensor 90 deg.
<b>Resolution:</b> 310 TV Lines.	<b>Motion detection range:</b> 20 ft. at 6 ft. height.
<b>Scanning:</b> 2:1 Interlace.	<b>Power Required:</b> 120 Volts AC.



**FCC Caution**

THIS DEVICE COMPLIES WITH PART 15 OF THE FCC RULES.  
OPERATION IS SUBJECT TO THE FOLLOWING TWO CONDITIONS:

- (1) THIS DEVICE MAY NOT CAUSE HARMFUL INTERFERENCE, AND
- (2) THIS DEVICE MUST ACCEPT ANY INTERFERENCE RECEIVED, INCLUDING INTERFERENCE THAT MAY CAUSE UNDESIREED OPERATION.

**NOTE:** Modifications to this product will void the user's authority to operate this equipment.

